

Different Types of Web Bracing Shown on TrusSteel Drawings

(This depiction is for illustration purposes only.)

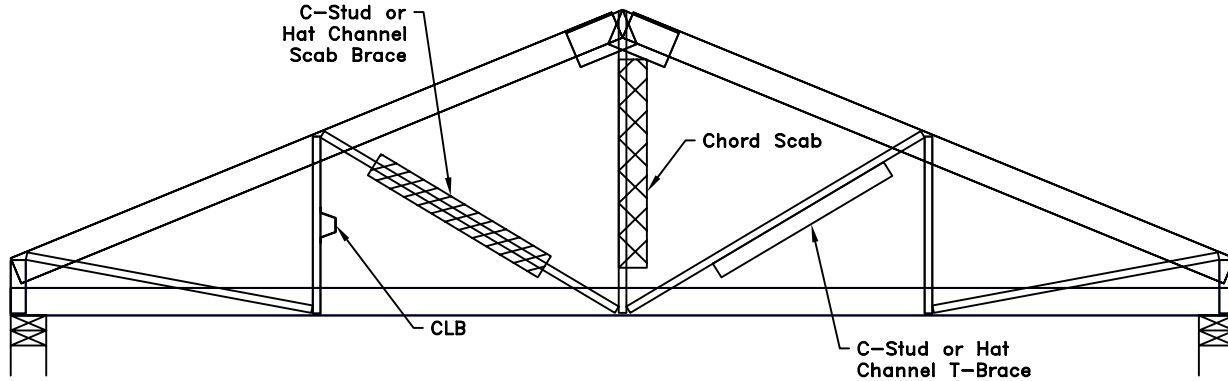

Chord Scab

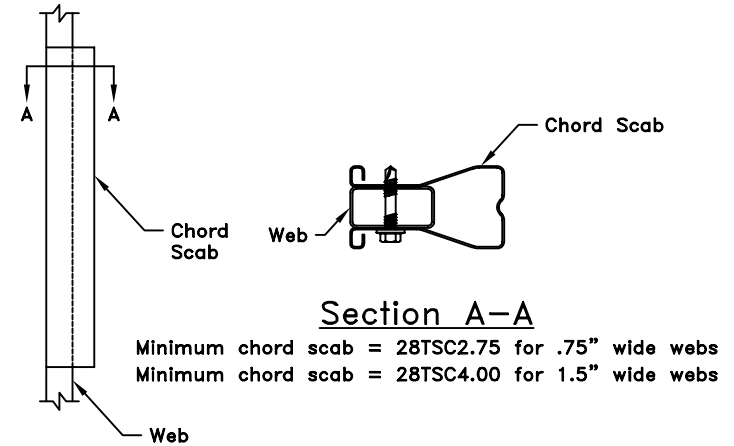

Continuous Lateral Brace (CLB)

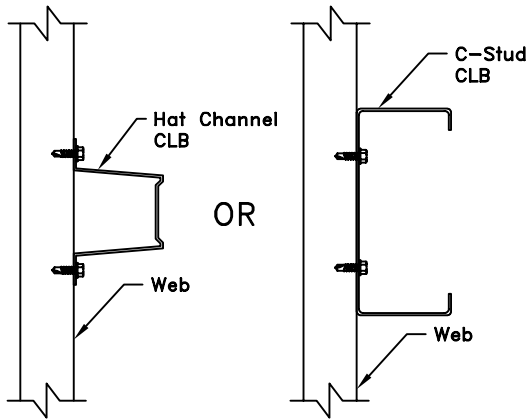

Minimum CLB = 150F125-33 or 362S162-33

See TS015 for Steel Truss Temporary and Permanent Bracing Guidelines.

See TS017 for Web CLB Restraint.

C-Stud or Hat Channel T-Brace

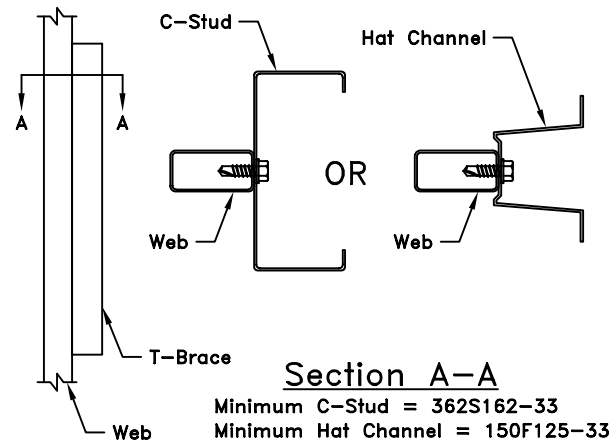

C-Stud or Hat Channel Scab Brace

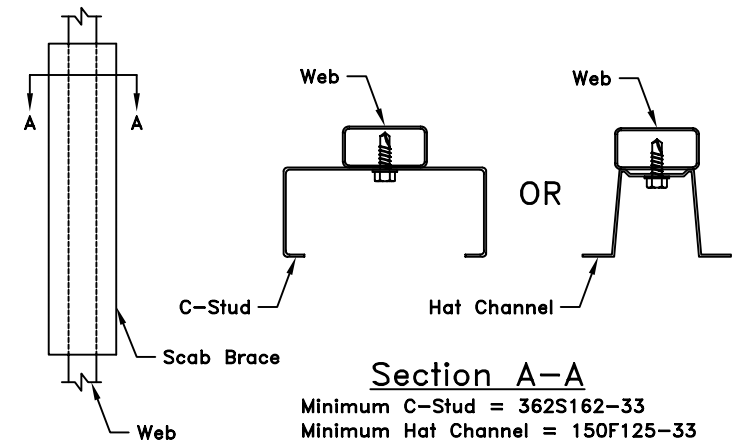

General Notes:

- 1) The details on this page are generic installation guides only. See approved truss drawings for specific brace material, size and connection requirements.
- 2) Web bracing called out on the approved truss drawings may NOT be substituted for a different brace type unless approved by a TrusSteel engineer.



www.TrusSteel.com

Florida: 1950 Marley Drive / Haines City, FL 33844 / (800) 755-6001
 Missouri: 13389 Lakefront Drive / Earth City, MO 63045 / (800) 326-4102
 California: 8351 Rovana Circle / Sacramento, CA 95828 / (800) 877-3678

General Web Reinforcement Guidelines

ITW Building Components Group, Inc. shall not be responsible for any performance failure in a connection due to a deviation from this detail. Any variation from this detail shall be approved in advance by ITW Building Components Group, Inc.

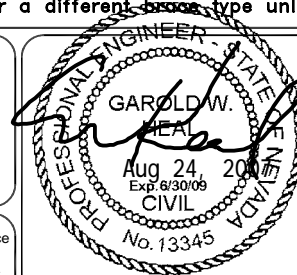

Standard Detail:

TS019

Date:

06/21/07

TrusSteel Detail Category:

Bracing