

TSC2.75

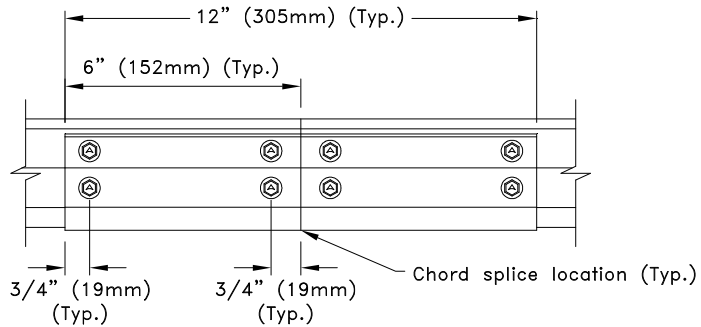

Detail A

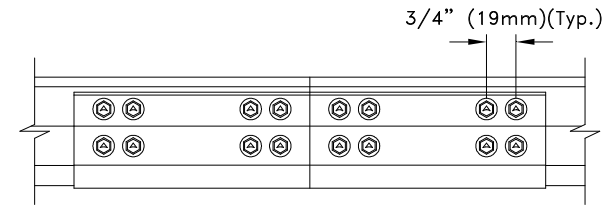

Detail B

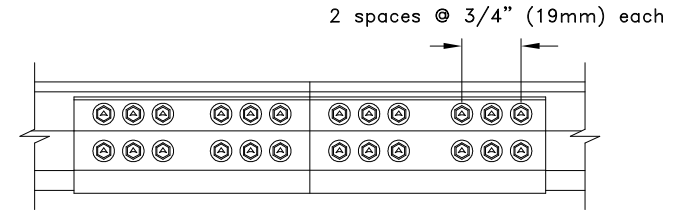

Detail C

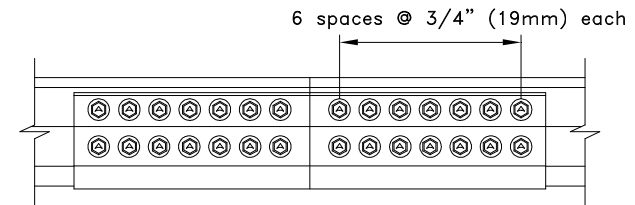

Detail D

General Notes:

1. Fastener spacing and end distance is 3/4" (19mm) minimum.
2. Fasteners may be 14AMS.75 or 14AMDR1.5. Refer to approved truss drawings for fastener type and detail call out.
3. Dimensions are typical for both sides of splice per splice detail.



Division of ITW Building Components Group, Inc.

www.TrusSteel.com

Florida: 1950 Marley Drive / Haines City, FL 33844 / (800) 755-6001
Missouri: 13389 Lakefront Drive / Earth City, MO 63045 / (800) 326-4102
California: 8351 Rovana Circle / Sacramento, CA 95828 / (800) 877-3678

**TSC2.75 Splices Using The
TS68UP2 Universal Piece**

ITW Building Components Group, Inc. shall not be responsible for any performance failure in a connection due to a deviation from this detail. Any variation from this detail shall be approved in advance by ITW Building Components Group, Inc.



Standard Detail:

TS002B

Date:

06/25/07

TrusSteel Detail Category:

Chord Splices