

1 Clip Connection*

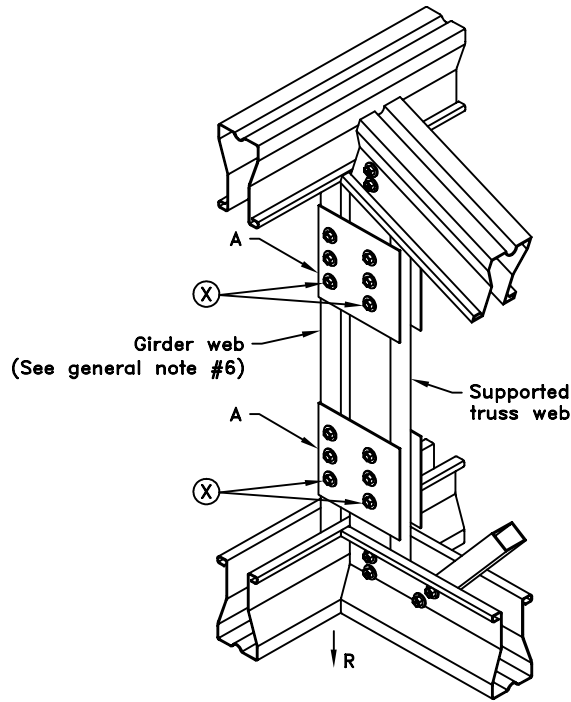

2 Clip Connection**

(R) Max = (U) Max lbs. (kN)	Number of "A" Clips	⊗
988 (4.39)	1	3
988 (4.39)	2	2
1482 (6.59)	1	4
1482 (6.59)	2	2
1976 (8.79)	1	5
1976 (8.79)	2	3
2470 (10.99)	1	N/A
2470 (10.99)	2	3

* Use one "A" clip when supported truss height is less than 4'(1219mm) or supported truss reaction is less than 1976lbs (8.79kN)

** Use two "A" clips when supported truss height exceeds 4'(1219mm) or supported truss reaction exceeds 1976lbs (8.79kN)

TSC2.75 Chord Trusses
A - TTC5 Clip

TSC4.00 Chord Trusses
A - TTC7 Clip

General Notes:

1. Screw spacing, edge distance and end distance is 5/8" (16mm) minimum.
2. The supported truss must be designed utilizing a clip bearing type.
3. R = Reaction and U = Uplift.
4. Girder and supported truss must have same chord size (i.e. TSC2.75 or TSC4.00).
5. ⊗ represents the number or #10SDS (self-drilling tapping screws) per clip face.
6. Girder webs must be 33W.75x.75 for TSC2.75 trusses or 33W1.5x1.5 for TSC4.00 trusses.
7. TTC clips are 20ga ASTM A653 SS grade 33. Bare metal thickness is 0.0329" (0.84mm) minimum.
8. For situations not covered by this detail, contact a TrusSteel engineer.



www.TrusSteel.com

Florida: 1950 Marley Drive / Haines City, FL 33844 / (800) 755-6001
 Missouri: 13389 Lakefront Drive / Earth City, MO 63045 / (800) 326-4102
 California: 8351 Rovana Circle / Sacramento, CA 95828 / (800) 877-3678

Truss-To-Truss Connection
Using TTC Clips (1 Ply Girder)

ITW Building Components Group, Inc. shall not be responsible for any performance failure in a connection due to a deviation from this detail. Any variation from this detail shall be approved in advance by ITW Building Components Group, Inc.

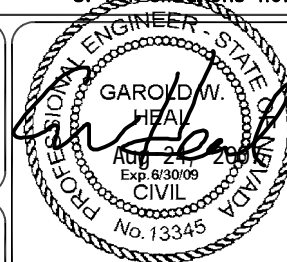

Standard Detail:

TS001A

Date:

06/07/07

TrusSteel Detail Category:

Truss-To-Truss Connections